

METOLIGHT® LED-Tubes Series Veg - for Fruit & Vegetables

Extra high Color Rendering CRI Ra>95 - 4300K

LED tubes Veg series are specially designed to produce the displayed goods in their real colors in sales counters with fruit and vegetables. They can be used directly in luminaires with magnetic ballast and starters without luminaire conversion. In the case of luminaires with ECG, however, this must be removed by a qualified electrician and the luminaire must be rewired. For this we recommend our adapter clamp Art.101606, with which the conversion can be completed in a few minutes.

The METOLIGHT® Veg is available in the usual T8 lengths of 60/90/120/150 cm. Special lengths are possible considering minimum quantities.

ASMETEC's Veg series offers especially designed LED tubes that are characterized by almost true daylight color with a CRI Ra> 95 in 4300K color. In contrast to conventional fluorescent tubes with high UV content, the food is reproduced here in its natural colors. In addition, these LED tubes have no UV light, which is proven to damage food and even change the taste.

Due to the high color rendering of the LED tubes, they can also be used in other areas where natural color reproduction is important, e.g. for textiles, curtains, wallpaper, galleries, libraries, boutiques, shops, hotels, restaurants and more.

All LED tubes of the Veg series are characterized by these special features:

- Replacement for T8 / T10 fluorescent tubes 60/90/120/150 cm corresponding to 18/30/36/58 Watt
- Up to 70% energy savings compared to conventional fluorescent lamps
- Very high color rendition with CRI Ra> 95
- Rotatable G13 base, rotatable and fixable, rotatable through 180 °
- Double insulated, replaceable power supply, power factor> 0.95
- Average lifetime up to more than 30,000 operating hours
- Full brightness without flickering or preheating right from the start , without 50 Hz flicker
- High shock and vibration resistance, largely shatterproof
- Free from UV light, only low IR light radiation - no bleaching of illuminated objects
- Aluminum core PCB, heat conduction gel, aluminum support tube for efficient heat management.
- Minimum heat output through high energy efficiency -> 100 lm / W
- CE, FCC and RoHS compliant, no hazardous waste, no mercury, no lead
- Energy class F
- Up to 3 years warranty (see warranty conditions)

Quality inspection, measurement of phototechnical and electrical data, creation of light distribution curves according to IES by batch and, if requested, per customer order in our own METOLIGHT® test laboratory at ASMETEC in Kirchheimbolanden.

METOLIGHT® is a registered trade mark of ASMETEC GmbH

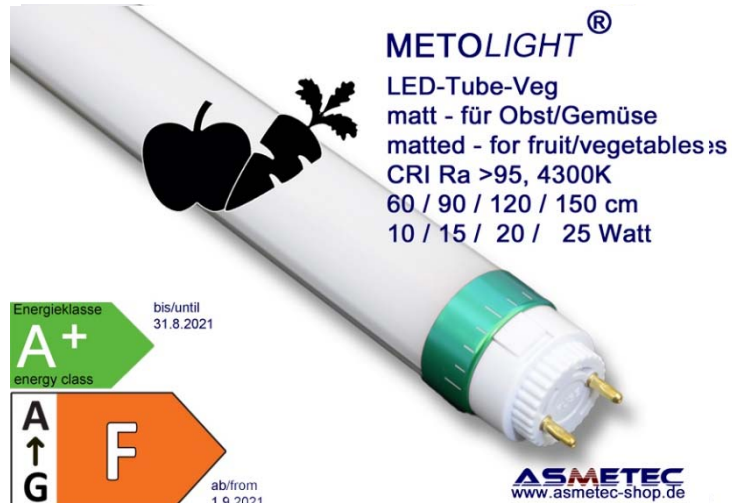

Sizes

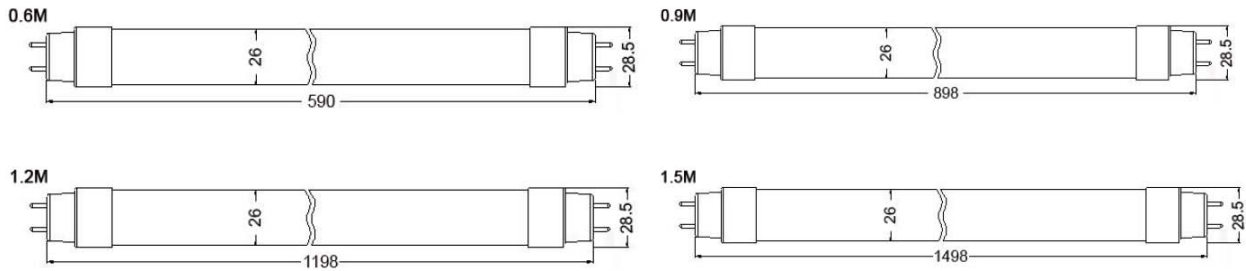

Technical data

Typical values, typical tolerance 5%

	60 cm	90 cm	120 cm	150 cm
Sizes				
Length A – Body	590 mm	898 mm	1198 mm	1498 mm
Length B – with pins	595 mm	902 mm	1206 mm	1505 mm
Length C – over all	610 mm	910 mm	1210 mm	1510 mm
Diameter body	25,6 mm			
Diameter end cap	26,5 mm			
Weight	220 g	290 g	320 g	380 g
Light Data				
Light power	1000 lm	1500 lm	2000 lm	2500 lm
Qty LEDs	50	72	110	144
Efficacy	> 100 lm/Watt			
Color rendering	CRI Ra > 95			
Average lifetime	L70B10 > 30.000 h für LED			
Beam angle	120°			
Light colour	Nature white, 4300K			
Available shells	matt (M) (optional clear)			
Electr. Data				
Input voltage	180 – 260 V AC			
Frequency	50 / 60 Hz			
Power	10 W	15 W	20 W	25 W
Input current (230V)	< 0,04 A	< 0,07 A	< 0,086 A	< 0,11 A
Power factor	Pf 0,95			
Isolation voltage	> 2500 V			
Switch cycles	> 100.000			
Protection built in	Over temperature, short break			
Energy class	F / EEI 0,13			
Dimmable?	No			
Work conditions				
Ambient temperature	-20°C - +40°C			
Storage temperature	-25 - +60°C			
Rel. Humidity	< 90 rH			
Protection class	IP20			
Complies with	EN 62776:2015, EN 62493:2015, EN 62471:2008, EN 55015, EN 60598-1:2008, EN 61000-3-2, EN 61547:2009, EN 62321:2001			
Complies with	CE, RoHS			
Notes	 <p>Use only in dry indoor areas Do not operate in hermetically sealed lamps Do not operate on dimmers Installation only while wires are powered off Operate magnetic ballast with LED starter only Not suitable for electronic ballast Not suitable for alkaline cleaning agents Do not use in an alkaline environment</p>			

The above statements are based on our present knowledge. Our statements should not be interpreted as a guarantee of characteristics. The use of our products by our customers is subject to different conditions, therefore none of our customers are relieved of the responsibility of testing our products by themselves. A liability for consequential damage will not be accepted in any case. For damage resulting from the use of this information we can only be held responsible if there is evidence of malice or negligence on our part. This data-sheet replaces any previous data sheets.

ASMETEC, METODRILL, METOCHECK, METOLIGHT, METOSTAT, METOCLEAN and METO are registered trade marks of ASMETEC GmbH.

LED-TUBE-VEG-DB-E.DOCX, VERSION MAI-21

Swiveling, lockable sockets - ideal for precise light alignment (similar to pictures)

Slide plastic lock forward -> turn socket -> push lock back

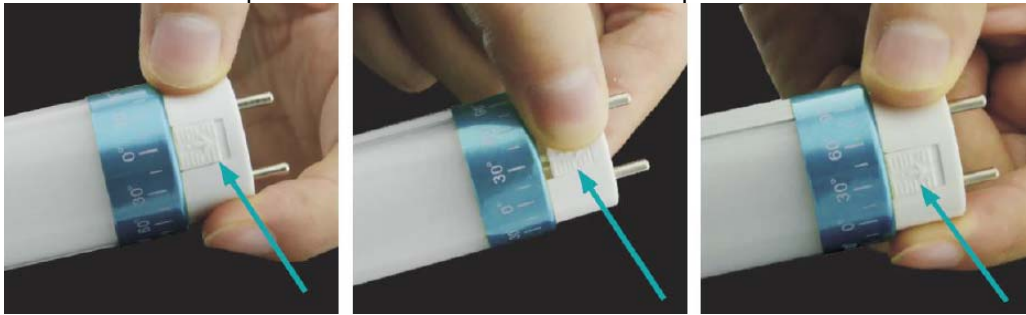

Note:

For each type of our LED tubes we provide technical data sheets with photometric and electrical data as well as light distribution curves for use in e.g. DIALUX for light calculation.

Installation instruction with luminaires with magnetic ballast

- The Veg LED tubes are only intended for lights with magnetic ballast and starters, as well as for luminaires specially prepared for LED tubes.
- Never operate in luminaires with electronic ballasts and / or dimmers.
- Do not make any technical changes to the luminaires.
- The LED tubes cannot be used for all applications in which fluorescent tubes have been used so far (for example, hazardous areas, EL areas, limited temperature range).
- If you have any questions, please contact Asmetec GmbH
- The LED tubes are suitable for general lighting tasks.
- Never replace the LED tubes with the lights powered on, the overvoltage of the ballasts can irreparably destroy the LED tubes.
-

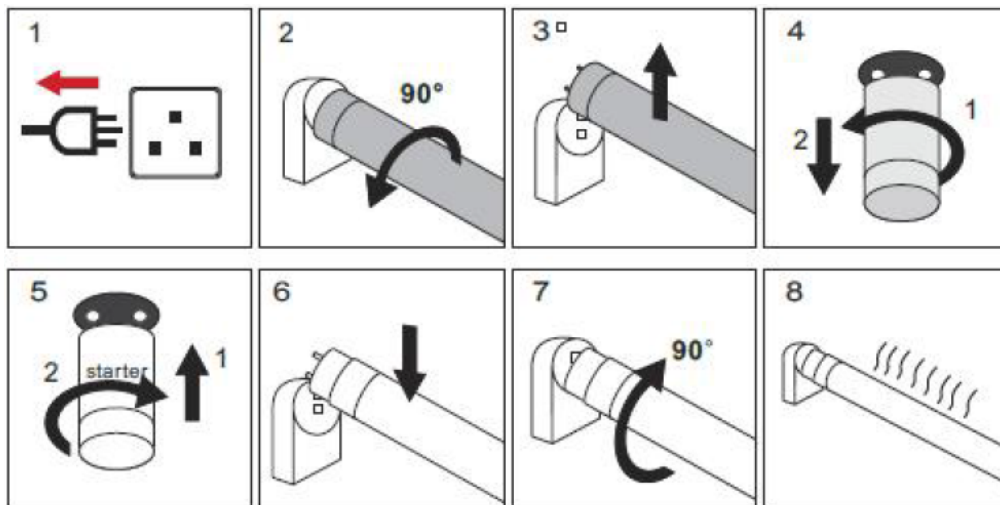

1. Power off the laminare
2. Turn CFL tube for 90 degrees
3. Take out CFL tube
4. Take out CFL starter
5. Insert LED starter and turn 90°
6. Install **METOLIGHT**® LED-tube (do not care for direction)
(in case you can rotate the end caps up to 180° and insert the tube again)
7. Turn LED tube for 90°
8. Power on laminare

Trouble shooting (LED-tube does not light up)

- Are mains power, G13 socket and the luminaire ok?
 - Is the LED-tube and starter correctly inserted?
 - Test the starter and the opposite side of tube (not the input side) with Ohm meter, it must be low ohmic
 - Test LED-tube and starter in another luminaire.
- In case the tube lights up, then the problem is in the luminaire.
In case the tube does not light as well, the tube might be defect, please return to Asmetec.

Installation of LED tubes (General Information)



When changing fluorescent tubes to LED tubes, there are a few basic things to keep in mind first:

1. Work on electrical / electronic devices may only be carried out by suitably trained specialist personnel.
2. Only change bulbs when the lights are switched off. Make sure that the power supply cannot be switched on accidentally while working on the lights (for example, by a corresponding sign on the safety cabinet). In the case of voltage-controlled luminaires, there is not only the risk of electric shock (ballasts can be charged up to 1500 volts), but also the possibility that lightning discharge of the ballasts irreparably damages the LED tubes.
3. Check whether the LED tube is suitable for the luminaire (voltage, CCG, electronic ballast)
4. If the G5 / G13 sockets of the luminaires are difficult or even mechanically damaged, they must be replaced.
5. The G5 sockets are approved for a maximum weight of 250 g, the G13 sockets for a maximum weight of 500 g. If the LED tubes are heavier than the permissible weight, they must be secured by additional fastening. In free-standing luminaires, we generally recommend attaching the LED tubes using two cable ties and adhesive pads or matching metal brackets.
6. When using Metolight TRF LED tubes (suitable for electronic ballasts), always check whether the existing ECG also matches the LED tubes. There are standard and HO versions for T5 tubes. These must not be reversed. Multi-range ECGs and dimmable electronic ballasts are not suitable for TRF tubes.
7. Check the temperature of the LED tubes approx. 5 cm from the base end with an IR thermometer after approx. 30 minutes of illumination. The temperature must not exceed approximately 50 ° C. Too hot LED tubes are an indication that either the ballast does not match the tube or that it is at the end of its operating time, thus giving different voltages and frequencies than when new.
8. With 10,000 operating hours and more, we generally recommend the expansion of ECGs and the use of LED tubes for direct connection to 230 V AC.

Example of energy class label 120 cm:

